



Merlin WCM

Water Check Monitor



INSTALLATION & OPERATION

Please read these instructions carefully before use and retain for future reference.

These instructions can also be downloaded in electronic form on the product website.

For specific requirements that may deviate from these instructions – contact your supplier.

americangassafety.com

Contents

Important Information	3
Copyrights	3
Manufacturer's Warranty	3
Disposing of Electrical & Electronic Equipment (WEEE)	3
Revisions	3
Safety Statements	4
Installation	4
General Description	4
Mounting & Cabling	4
Circuit Board Overview	5
Wiring – Power	5
Wiring – Water Valve	5
Wiring – Water Flow Meter	6
Wiring – External Intruder Alarm	6
Wiring – Output to BMS	7
Wiring – Sensors	7
Operation	8
Overview	8
Operating Mode: On	8
Operating Mode: Vacant	9
Operating Mode: Off	9
Operating Mode: Bypass	9
Water Leak Sensor Alarm / Fault	9
Menu Mode	10
Internal Configuration Settings	11
Maintenance	12
Cleaning the Equipment	12
Technical Specification	12

Important Information

Copyrights

This manual is subject to copyright protection; all rights are reserved. Under international and domestic copyright laws, this manual may not be copied or translated, in whole or in part, in any manner or format, without the written permission of **American Gas Safety LLC**.

Manufacturer's Warranty

The manufacturer warrants to the original consumer purchaser, that this product will be free of defects in material and workmanship for a period of **3 years** from the date of purchase.

The manufacturer's liability hereunder is limited to replacement of the product with repaired product at the discretion of the manufacturer. This warranty is void if the product has been damaged by accident, unreasonable use, neglect, tampering or other causes not arising from defects in material or workmanship. This warranty extends to the original consumer purchaser of the product only. Any implied warranties arising out of this sale, including but not limited to the implied warranties of description, merchantability and intended operational purpose, are limited in duration to the above warranty period. In no event shall the manufacturer be liable for loss of use of this product or for any indirect, special, incidental, or consequential damages, or costs, or expenses incurred by the consumer or any other user of this product, whether due to a breach of contract, negligence, strict liability in tort or otherwise. The manufacturer shall have no liability for any personal injury, property damage or any special, incidental, contingent, or consequential damage of any kind resulting from gas leakage, fire, or explosion. This warranty does not affect your statutory rights.

During the above warranty period, your product will be replaced with a comparable product if the defective product is returned together with proof of purchase date. The replacement product will be in warranty for the remainder of the original warranty period or for six months – whichever is the greatest.

Disposing of Electrical & Electronic Equipment (WEEE)

When this product has reached the end of its life it must be treated as Waste Electrical & Electronics Equipment (WEEE). Any WEEE marked products must not be mixed with general household waste, but kept separate for the treatment, recovery and recycling of the materials used.

Please contact your supplier or local authority for details of recycling schemes in your area.

Revisions

Every effort is made to ensure the accuracy of this document; however, **American Gas Safety LLC** can assume no responsibility for any errors or omissions in this document or their consequences.

AGS would greatly appreciate being informed of any errors or omissions that may be found in the content of this document. For information not covered in this document, or if there is a requirement to send comments/corrections, please contact **AGS** Northern Limited.

Safety Statements



Take extra care where this symbol is used throughout this document to understand the nature of potential hazards and how to avoid them.

- ⚠ Before any installation, use or maintenance read this manual carefully.
- ⚠ The information contained within this manual should be referenced for typical installation and operation only.
- ⚠ For site specific requirements that may deviate from the information in this guide – contact your supplier.
- ⚠ If the equipment is used in a manner not specified by the manufacturer, the safety and protection provided by the equipment may be impaired.
- ⚠ Installation must be in accordance with recognised standards in the country concerned.
- ⚠ Cables must be protected against mechanical damage.
- ⚠ This device requires a continual supply of electrical power – it will not work without power.
- ⚠ A switch or circuit breaker must be fitted, it must be accessible and marked as the disconnecting device!

Installation

General Description

- ⚠ **Installation must be in accordance with recognised standards in the country concerned.**

The Water Check Monitor (WCM) is designed to check the water usage by monitoring the pulsed output from a connected water meter with a pulse/litre output.

The user should take special care when setting up the maximum flow allowances to evaluate a leak condition compared to the allowable water flow time. Water leak detection ropes or puck sensors can be connected to up to three zones and can be easily reset once a water leak has been rectified.

Mounting & Cabling

- ⚠ **If mounting direct to wall - ensure the wall surface is flat to prevent base distortion!**
- ⚠ **Where suitable cable glands/conduits are used for wire entry, use 20mm (3/4 inch) separated by at least 20mm!**

1. Carefully remove the front cover from the unit by using an M3 hex wrench.
2. Using the rear base - mark mounting holes to the wall or align with an appropriate gang/pattress box.
3. Fixing straight to wall – drill 0.2” (5mm) hole, insert plugs and use the four screws (No.4 Pozi) provided. Alternatively – Fix direct to a vertical 2-gang/double electrical pattress box.
4. There are pre-fractured areas for cable entry on the rear of the base and pilot holes positioned on the top and bottom of the enclosure suitable for entry points up to 3/4” (20mm). Drill out as necessary ensuring all swarf is removed from the box and holes have smooth edges.
5. Secure the front cover with all M4 bolts and insert security caps provided.

Circuit Board Overview

- ⚠ **Damage to PCBs when creating cable entry points may void any warranty.**
- ⚠ **Take care when making connections to high voltage connectors.**
- ⚠ **Any damage attempting to remove the circuit board may void any warranty.**
- ⚠ **All Class 2 wiring is to be installed within flexible tubing to maintain segregation between circuits.**
- ⚠ **Wiring of different circuits shall be separated by means of routing, clamping or barrier.**
- ⚠ **A switch or circuit breaker must be fitted, it must be accessible and marked as the disconnecting device.**
- ⚠ **Restrain the hazardous live wiring from accidental loosening to prevent wires from moving after installation and touching parts of opposite polarity or at low voltages.**
- ⚠ **A switch or circuit breaker must be fitted, it must be accessible and marked as the disconnecting device.**
- ⚠ **Isolate the equipment from all hazardous live power sources before opening the cover.**

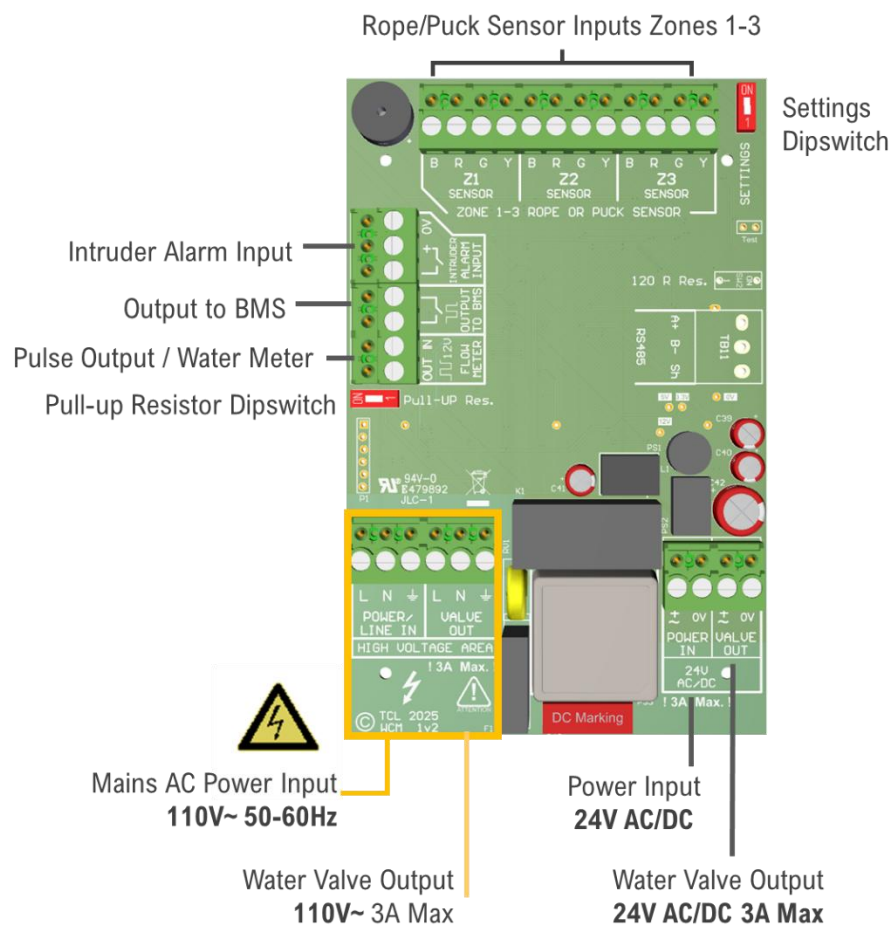

Note: Valve voltage and input voltage must match

Wiring – Power

The controller requires a power supply of either 24VDC/AC (21.5 – 26.5V) connected to [24V AC/DC POWER IN] terminal or mains AC (110V~) connected to the [POWER/LINE IN] terminal using a 3A switched fused spur.

Wiring – Water Valve

- ⚠ **Use earth terminals for water valves not considered class II apparatus.**
- ⚠ **The valve voltage rating must match the input voltage used.**

A water solenoid valve should be powered using the terminals marked [VALVE OUT] with 110VAC or 24VAC/DC.

Wiring – Water Flow Meter

A suitable water meter must be used with a maximum of 1 pulse per litre. Please contact AGS representative for additional information about compatible water meters.

The water meters pulsed output must be connected to the terminals marked [OUT] & [IN] with the [Pull-Up Res] dipswitch in the 'Off' position.

If a non-standard water meter has been used, such as a Honeywell type with a retrofittable pulse module, it may require a pull-up resistor. In this instance connect [0V] & [IN] and ensure the [Pull-Up Res] dipswitch is in the 'ON' position.

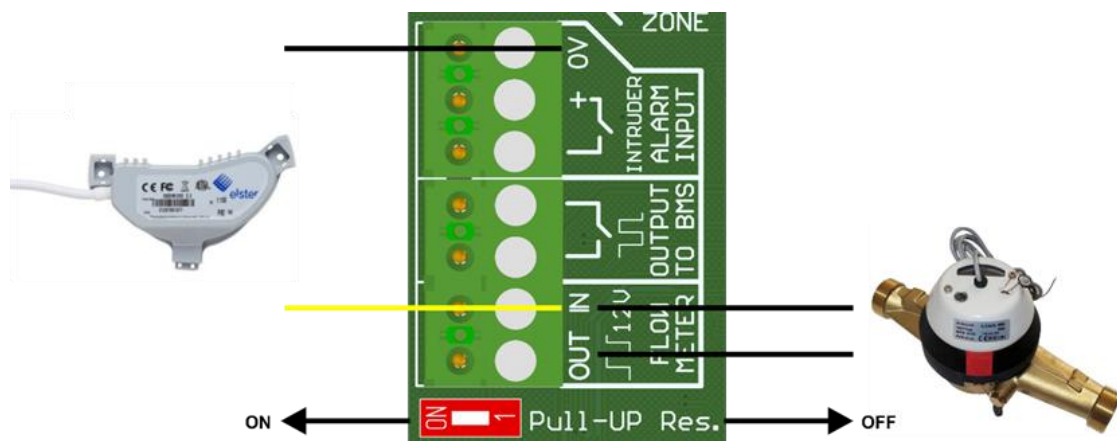

Refer to the water meter for more information.

Wiring – External Intruder Alarm

An external intruder alarm can be wired to the WCM to automatically activate the VACANT mode. If the external alarm is providing 12VDC on activation, it can be connected to the + and 0V contact.

Alternatively, the switch contact (volt free input) can be connected if the intruder alarm is activated via a switch.

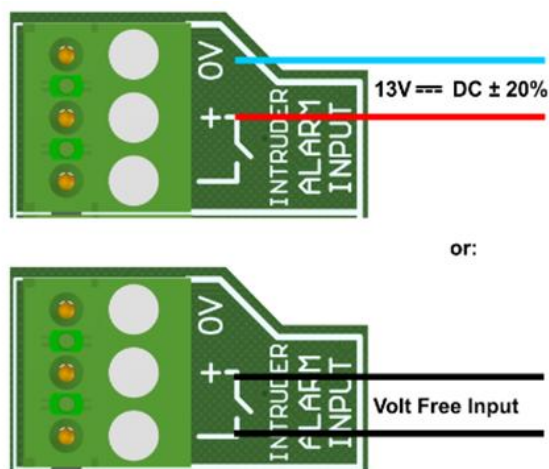

Note: From the settings menu, the intruder alarm delay can be enabled or disabled, and an activation delay in minutes can also be set.

Wiring – Output to BMS

Connect an external buildings management system (BMS) or M-Bus system to monitor the pulses from the water meter, connect to the + and 0V terminals.

Wiring – Sensors

The WCM is compatible with 4 and 2 wire leak detection ropes wired to the [SENSOR] terminal. This terminal has a factory fitted link (R & Y) and should be removed when 4 wire rope is used.

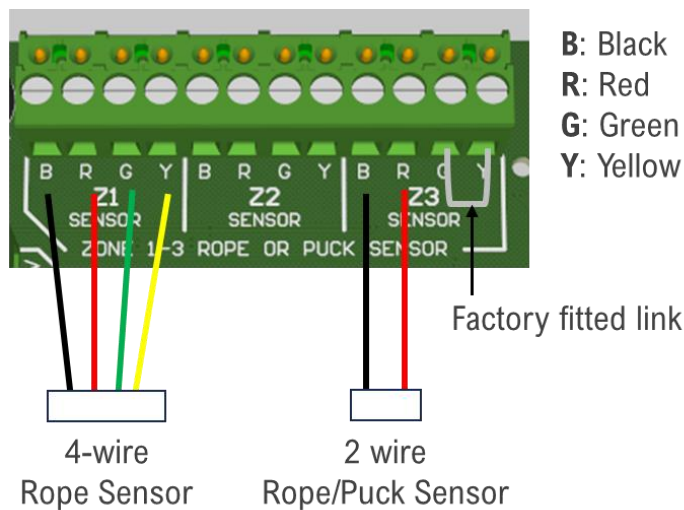

The detection cable can make a timely and accurate response to the leakage of water, weak acid and weak alkali liquid. The cable is small and light, flexible and easy to install. Both ends are equipped with quick transfer terminals, which can be extended quickly.

Other rope/cable considerations when laying. Avoid:

- Using glue compounds
- Laying near or round sharp objects
- Direct contact with metal objects/surfaces
- Installation near air conditioners and other appliances/environments at risk of causing false alarms

Operation

Overview

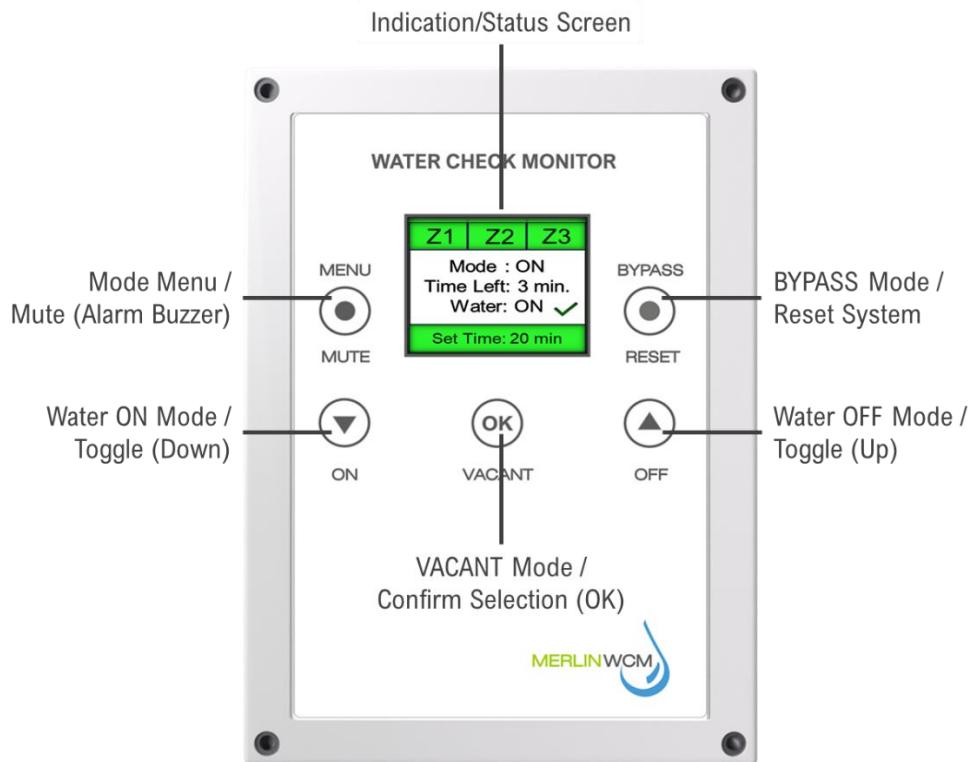

The WCM has 4 operating modes:

On - For normal use when the property is occupied, this will time the water flow when in use.

Off - Will turn OFF the water supply directly.

Vacant – Isolates the water supply when the property is vacant for extended periods, such as holidays/vacations.

Bypass - Allows water usage beyond any mode timer.

Operating Mode: On

The WCM will monitor all leak detection zones, and the maximum allowed water flow time in minutes.

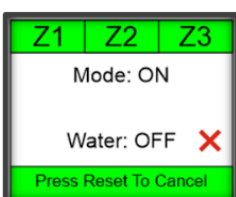

When water is being used (shower, toilet, tap etc.), the water flow Set Time will initiate, if the water is still flowing beyond this time, and the timer reaches zero, the water valve will close, and no water will be available. This can be reset by pressing the RESET button. (ensure there are no actual water leaks).



If the water being used is turned off (i.e. tap turned off) within the water flow Set Time, the vacant timer will automatically be prompted until water is used again (Set Time re-triggers).

When the vacant timer reaches zero (no water has been used), the WCM will automatically switch to Vacant Mode. The timer is reset every time water is used.

Operating Mode: Vacant

This mode can be selected by pressing the VACANT button.

One of the following two functions can be configured from the Menu. Either; -

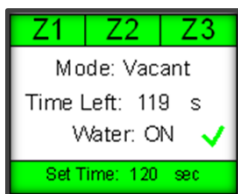

Water Off

Will turn the water OFF (valve closed) immediately when the Vacant button is pressed, or,

Max Flow

This will allow water usage within a timed range of 0 - 120s. When zero is reached, the water valve will close (Water Off).

Operating Mode: Off



Press the OFF button to turn off the water supply (valve closed).
Press RESET to turn the water supply back on (valve open).

Operating Mode: Bypass

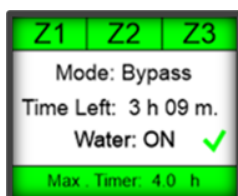

Bypass all other modes for a set period, ignoring all water flow usage timers.

Select by pressing the BYPASS button.

When the Bypass timer reaches zero, the device will automatically switch to ON mode.

Water Leak Sensor Alarm / Fault



When a water leak sensor alarm is activated, the MUTE button can be pressed to turn off the audible alarm. Once the leak is investigated and rectified, the RESET button must be pressed to reset the system.

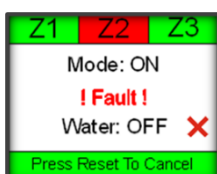

If the leak detection rope is faulty a message will be displayed as follows, the rope sensor should be repaired or replaced and system Reset.

Menu Mode

Press the MENU button to select the configuration screen.

Use the arrow buttons to scroll and highlight the required mode, highlighted red, press OK to select it.



Menu: Water ON Mode

Press OK to select the required setting turning the unit red, now use the arrow keys to adjust it and confirm by pressing OK.

Function	Description	Parameter	Default
Max.FL Time (m)	Maximum allowed water flow (in minutes) during normal usage. Upon timeout, the water valve will close (Water Off)	0~ 30 min	30 min
OFF Timer (h)	If no water flows during the set timed countdown, the water valve will be automatically turned off after this period. (Hours)	0-48 hours	24 hrs



Menu: Vacant Mode

Press OK to select the required setting turning the unit red, now use the arrow keys to adjust it and confirm by pressing OK.

Function	Description	Parameter	Default
Max.FL time (s)	Only when Mode is set to Max.Flow Maximum allowed reduced water flow when the property is vacant, when exceeded the water valve will close. The timer is reset every time the water is turned off, the water is deemed as being off when usage is <1 Ltr within a set period (s) this can be adjusted in the settings VacMaxFl.Cyc s.	0~120s	120s
Mode	Select response. Max.Flow: allow a reduced water user to be set. Water off: directly turns off water when Vacant Mode selected.	Max. Flow / Water Off	Water Off

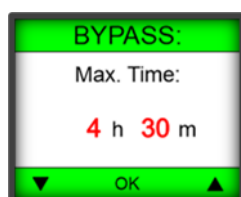

Menu: Bypass Mode

Using the arrow keys adjust the Bypass time and press OK to confirm it.

Function	Description	Parameter	Default
Bypass	Set the time to bypass the Water ON and Vacant modes allowing as much water usage without isolating the supply.	30min~48hrs	24hrs

Scroll to Exit and press OK to close any menu screen.

Internal Configuration Settings

To access the settings, switch the settings dipswitch on the circuit board.

When turned on, the settings screen will be displayed.

Use the arrow keys to scroll through (indicated in red), press OK to highlight the unit and adjust again with arrow keys, confirm by pressing OK.

Z1 Sensitivity %	50	Intruder Alarm	OFF
Z2 Sensitivity %	50	Intruder delay m.	15
Z3 Sensitivity %	50	VacMaxFI.Cyc s.	30
Valve Test days	30	---	
Buzzer	Const.	Factory reset	

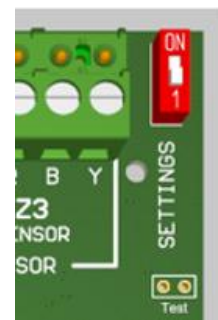

The following parameters can be adjusted as follows:

Setting	Description
Z1 - Z3 Sensitivity %	Zone rope leak sensitivity (10-90%) factory set at 50%. The sensitivity can be adjusted for zones 1~3. It is recommended to check the sensitivity for longer runs of leak detection rope over 100m. If an alarm condition cannot be reset once cleared, then check the sensitivity.
Valve Test Days	Valve Test (0-90) factory set at 30 days. This is the period when the system will automatically exercise the water valve to ensure that it does not seize up when the property is vacant, i.e. water valve closed.
Buzzer	Audible Buzzer Pattern. (If the buzzer dipswitch is on). Const. = Continuous sound in alarm, (Default). 30sec. = 3 Beeps every 30 seconds.
Intruder Alarm	On (Default). Allowing for an external intruder alarm to activate Vacant mode.
Intruder Delay min	Set the delay time (0-20 minutes), factory set at 0 minute, before automatically switching to Vacant mode via the external linked intruder alarm is set.
VacMaxFI.Cyc s.	Adjustable (10-60 sec) factory set at 30sec Timer to evaluate when the water has been turned off in Vacant mode, when no water has been used within this set period the Vacant Max. FI timer will reset.
Factory Reset	Reset all settings to the factory set conditions

From the settings screen use the arrows key to select the required setting, it will be indicated in red, press OK to select it turning the unit red, now use the arrow keys to adjust it and confirm by pressing OK.

Once all settings have been configured turn off the setting dipswitch to return to normal operation.

Maintenance

Cleaning the Equipment

Keep your device in good working order

- Remove any dust/debris from the outer enclosures regularly using a slightly damp cloth.
- Never use detergents or solvents to clean your device(s).
- Never spray air fresheners, hair spray, paint or other aerosols near the device.
- Never paint the device(s). Paint may seal any vents and interfere with the equipment.

Technical Specification

General	
Model:	WCM – Water Check Monitor
Size: (H x W x D)	151 x 111 x 50mm (5.95 x 4.37 x 1.97”)
Mounting:	Wall/Surface Mounted. Indoor use only
Weight:	320g (11.2 oz)
Max Length: Leak detection rope sensor	300M
User Interface	
Visual Indicators:	Display - Water On / Leak / Water flow
Audible Buzzer:	>60dB @1m (3.28ft). Quiet conditions.
Buttons:	Mute / Reset / Bypass / Vacant / Arrow adjustment / OK
Power Supply	
Power Consumption:	1.2W Max
Power Input #1:	100-240V~ 50-60Hz
Internal Fuse:	Resettable Fuse 2.5A @ 250Vac
Equipment	
Overvoltage Category:	II
Pollution Degree:	3 (Unit Only)
Environmental	
Operating temperature	0 ~ 50°C / 32 ~ 122°F 20 ~ 95% RH (non-condensing)
Approvals	
CE / UKCA	BS EN 61010-1 / BS EN 61326

American Gas Safety LLC

www.americangassafety.com

Head office:

6304 Benjamin Road, Suite 502, Tampa, FL 33634

Tel: (727) 608-4375

Email: info@americangassafety.com



American Gas Safety LLC is the owner of this document and reserves all rights of modification without prior notice.