

Merlin GM-100



INSTALLATION & OPERATION

Please read these instructions carefully before use and retain for future reference.

These instructions can also be downloaded in electronic form on the product website.

For specific requirements that may deviate from these instructions – contact your supplier.



americangassafety.com

Contents

Important Information	4
Copyrights	4
Manufacturer's Warranty	4
Disposing of Electrical & Electronic Equipment (WEEE)	4
Revisions	4
Safety Statements	4
Introduction	5
General Description	5
Key Features	5
Applications	5
Appearance	6
Replacement Parts List	6
Technical Specifications	7
Sensor Specifications	8
Carbon Monoxide (CO)	8
Nitrogen Dioxide (NO ₂)	8
Methane / Hydrogen / Propane, Butane (CH ₄ / H ₂ / LPG)	8
O ₂ Oxygen	9
Sensor Warnings	9
Installation	10
General Safety Cautions	10
EMI and RF Interference Considerations	10
Coverage	10
Positioning	10
Mounting Instructions	11
Circuit Board Overview	12
Power & Digital RS485 Wiring	12
Analog Output Wiring	13
Operation	14
Initial power-up	14
LED Indication Status	15
User Button Functions	15
Manual Override	16
Temperature Alarm	16

Access Configuration Menu	16
Configuration List & Parameters	17
Default Sensor Alarms	18
End Of Life (Replace) Indication.....	18
Commissioning	19
Overview	19
Alarm Test.....	20
Maintenance.....	20
Service Reminder	20
Reset Service Reminder	20
Cleaning the Equipment	20
Replace or Disable Gas Sensor S1 or S2	21
Calibration	22
General Safety Statements.....	22
Calibration Procedure.....	22
System Bump Test	24
General information.....	24
Bump Test Procedure	24
Trouble Shooting.....	25
Fault Indications	25
Additional Information	25
Sensor Principle - Electrochemical.....	25
Sensor Principle - Catalytic	25
BACnet Functionality	26
Modbus Functionality	30

Important Information

Copyrights

This manual is subject to copyright protection; all rights are reserved. Under international and domestic copyright laws, this manual may not be copied or translated, in whole or in part, in any manner or format, without the written permission of **American Gas Safety LLC**.

Manufacturer's Warranty

The manufacturer warrants to the original consumer purchaser, that this product will be free of defects in material and workmanship for a period of **3 years** from the date of purchase.

The manufacturer's liability hereunder is limited to replacement of the product with repaired product at the discretion of the manufacturer. This warranty is void if the product has been damaged by accident, unreasonable use, neglect, tampering or other causes not arising from defects in material or workmanship. This warranty extends to the original consumer purchaser of the product only. Any implied warranties arising out of this sale, including but not limited to the implied warranties of description, merchantability and intended operational purpose, are limited in duration to the above warranty period. In no event shall the manufacturer be liable for loss of use of this product or for any indirect, special, incidental, or consequential damages, or costs, or expenses incurred by the consumer or any other user of this product, whether due to a breach of contract, negligence, strict liability in tort or otherwise. The manufacturer shall have no liability for any personal injury, property damage or any special, incidental, contingent, or consequential damage of any kind resulting from gas leakage, fire, or explosion. This warranty does not affect your statutory rights.

During the above warranty period, your product will be replaced with a comparable product if the defective product is returned together with proof of purchase date. The replacement product will be in warranty for the remainder of the original warranty period or for six months – whichever is the greatest.

Disposing of Electrical & Electronic Equipment (WEEE)

When this product has reached the end of its life it must be treated as Waste Electrical & Electronics Equipment (WEEE). Any WEEE marked products must not be mixed with general household waste, but kept separate for the treatment, recovery and recycling of the materials used.

Please contact your supplier or local authority for details of recycling schemes in your area.

Revisions

Every effort is made to ensure the accuracy of this document; however, AGS can assume no responsibility for any errors or omissions in this document or their consequences. AGS would greatly appreciate being informed of any errors or omissions that may be found in the content of this document. For information not covered in this document, or if there is a requirement to send comments/corrections, please contact AGS using the contact details given below.

Safety Statements

 Take extra care where this symbol is used throughout this document to understand the nature of potential hazards and how to avoid them.

Introduction

General Description

This equipment has been designed to meet the requirements of high specification requirements of customised solutions. Available with single and dual gas detection capability, designed for all areas being directly connected to low voltage supply. The equipment is to be installed in non-classified, non-hazardous, permanent locations and is intended to continuously monitor the ambient air for dangerous gas/air concentrations. The equipment can operate as a standalone unit, be connected to a control panel or direct to other 3rd party devices capable of accepting digital and/or analogue outputs, such as a Building Management System (BMS).

The equipment features two alarm levels, a selectable audible alarm, LED status and LCD display indicating power, alarm status, gas type, concentration, measurement, address, and fault conditions. Plug-and-play modular assembly allows for replaceable smart gas sensor modules. On delivery, the equipment is calibrated at ambient, normal conditions and configured for the specified gas, measuring range and alarms.

For any further information and technical support, contact your supplier.

Key Features

- ✓ Single or Dual channel operation.
- ✓ Factory calibrated field replaceable sensor modules.
- ✓ Two analog output signals in the range of voltage or current loop principle.
- ✓ One relay signal (1A)
- ✓ Digital RS485 communication – Modbus RTU or BACnet MS/TP – field selectable.
- ✓ Strong anti-interference circuit boards and RoHS compliant.
- ✓ Standard corrosion resistant enclosure

The equipment can be used indoors or in covered outdoor locations. If used outdoors, choose a sheltered location which is protected from direct sunlight, rain, and other extreme conditions.

Applications

Private homes • Apartment buildings • Condominium buildings • Parking garages • Schools • Hospitals • Commercial buildings • Shopping malls • Service centres • Retail • Offices • Hotels • Warehouses • Data centres • Food processing plants • Textile plants • Vehicle and machinery facilities • Warehouses • Vehicle Emissions (CO, NO₂) • Enclosed parking garages • Loading docks • Automotive maintenance facilities • Truck maintenance facilities • Fire stations • Ambulance bays • Boiler rooms • Warehouses • Food processing plants • Cold storage • Ice rinks • Landfills • Water and wastewater treatment plants • Recycle centres • Natural gas monitoring • Commercial kitchens • Laboratories • Warehouses • Lead acid battery charging stations • Swimming pool mechanical rooms • Medical labs • Hospitals • Welding facilities • Mechanical rooms • Compressor rooms.

Appearance

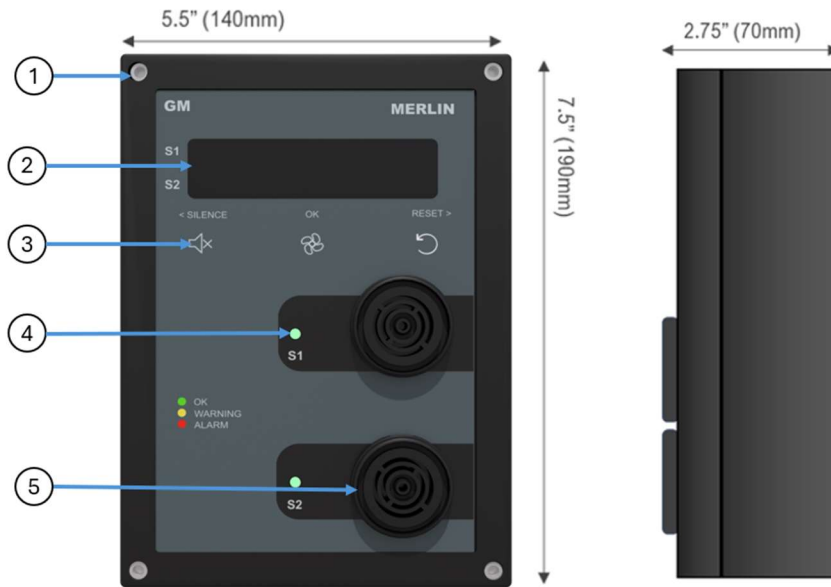

1	M4x15mm bolts	Secures front fascia decal.
2	LCD Display	Gas Type / Concentration / Unit / ID
3	User Buttons	Silence audible buzzer / Acknowledge alarm / Override / Navigate menu
4	LED Status Indication	Power-OK / Fault-Warning / Alarm / Calibration
5	Gas Sensor Opening	Allows diffusion monitoring of air and gas

Replacement Parts List

Part Number	Item
GDM-CO	CO: Carbon Monoxide Sensor
GDM-NO2	NO2: Carbon Dioxide Sensor
GDM-CH4	CH4: Methane (Natural Town Gas) %LEL
GDM-H2	H2: Hydrogen %LEL
GDM-LPG	LPG: Propane / Butane %LEL

Technical Specifications

Mechanical

Material	ABS Flame Retardant UL94 V0
Height	5.95" (151.2mm)
Width	4.37" (111.2mm)
Depth	1.97" (50mm)
Weight	350g / 12.5 oz

Electrical

Power – Low Voltage	Nominal 24V AC/DC (12-32)
Consumption - Low V	1.5 W
Wiring (RS485)	127 Units

IO

Digital Output x1	Modbus RTU or BACnet MS/TP (field selectable)
Signal Relay Output x1	1A, 60VDC
Analog Outputs x2	0/4-20mA or 0/2-10V (field selectable)

Environmental

Operating Temperature	-4° to 122°F (-20° to 50°C)
Humidity	15 to 90% RH (continuous) 0-99% (intermittent) non-condensing.
Atmospheric Pressure	6561ft (2000m)
Installation Category	III @ 24V~
Pollution Degree	2

User Interface

LED Indications x2	Power, Alarm Low, Alarm High, Fault, Calibration
Audible Alarm x1	>85dB
Button(s) x3	Silence Alarm / Reset Unit / Manual Override
Language	English

Certification/Conformance

Safety	UL/CSA/IEC/EN/BS 61010-1
Electromagnetic Compatibility	Directive 2014/30/EU / Regulation 2016 / EN 50270
FCC	This device complies with part 15 of the FCC Rules, Operation is subject to the following two conditions: (1) This device may not cause harmful interference, and (2) this device must accept any interference received, including interference that may cause undesired operation.
Gas Performance	UL 2075 (CO and NO ₂)

Sensor Specifications

Carbon Monoxide (CO)

Type	Electrochemical
Measuring Range	0-250ppm
Response (t90)	<30s
Resolution	1ppm
Stability / Year	<5%
Expected Lifecycle	7 years in clean air and regular maintenance.
Calibration	Every 6, 12 or 18-months dependant on application and climate.
Cross Sensitivity	Available on request
Repeatability	< ±3%
Deadband	≤ 3ppm
Accuracy	5% of applied concentration following correct calibration.

Nitrogen Dioxide (NO₂)

Type	Electrochemical
Measuring Range	0-10ppm
Response (t90)	<50s
Resolution	0.1ppm
Stability / Year	<20%
Expected Lifecycle	2 years in clean air and regular maintenance.
Calibration	Every 6, 12 or 18-months dependant on application and climate.
Cross Sensitivity	Available on request
Repeatability	< ±2%
Deadband	≤ 0.2ppm
Accuracy	5% of applied concentration following correct calibration.

Methane / Hydrogen / Propane, Butane (CH₄ / H₂ / LPG)

Type	Catalytic
Measuring Range	0-100% LEL (Lower Explosive Limit)
Response (t90)	<60s
Resolution	0.1%
Stability / Year	<20%
Expected Lifecycle	10 years in clean air and regular maintenance.
Calibration	Every 6, 12 or 18-months dependant on application and climate.
Cross Sensitivity	Sensitive to Hydrogen, LP (iso-butane) gas and organic vapours
Repeatability	< ±10%
Deadband	≤ 1.4%LEL
Accuracy	10% of applied concentration following correct calibration.

O2 Oxygen

Type	Electrochemical
Measuring Range	0-25% Oxygen
Response (t90)	<10 seconds
Resolution	0.1%
Maximum Overload	30% Oxygen
Stability / Year	5% over operating life
Expected Lifecycle	5 years
Calibration	Every 12 months
Deadband	21.5 ~ 20.7 % will be displayed as 21.0%

Sensor Warnings

- ⚠ Response time (t90) may increase when operating in lower temperature conditions.
- ⚠ All figures are valid over the temperature range -20°C to 50°C (-4 to 122°F)
- ⚠ If not used in accordance with these instructions, the safety of the equipment may be impaired.
- ⚠ Do not use in classified hazardous areas (explosion rated environments).
- ⚠ The equipment is shipped pre-calibrated to traceable standards and set to a factory condition.
- ⚠ It is recommended that this equipment be commissioned upon installation.
- ⚠ Concentrations of alcohol found in many products may damage, deteriorate, or affect gas readings.
- ⚠ The equipment is not designed to detect smoke, fire or other gases not specified.
- ⚠ Never ignore the equipment when in alarm or special state condition.
- ⚠ The equipment should not be used to substitute proper installation, use and/or maintenance of fuel burning appliances including appropriate ventilation and exhaust systems.
- ⚠ Multiple detectors may be required to adequately protect property and persons.
- ⚠ The equipment does not prevent dangerous gasses from occurring or accumulating.
- ⚠ Seek fresh air supply and contact your local gas emergency service should you suspect a gas leak.
- ⚠ This equipment may not fully safeguard individuals with specific medical conditions. If in doubt, consult a doctor/physician.
- ⚠ Do not apply lighter gas or other aerosols to the equipment – this may cause extreme damage.
- ⚠ Avoid environmental conditions outside of this specification that could potentially impede the accuracy and operation of the equipment such as condensation; vibration; temperature, pressure, the presence of other gases, electromagnetic interference, and draft zones.
- ⚠ The audible alarm will only sound if the buzzer switch is turned on.
- ⚠ Following over or under range indications, recalibrate the sensor to ensure continued accuracy.
- ⚠ Calibrate upon installation if in non-ambient conditions (i.e., extreme temperature or humidity).
- ⚠ The gas diffusion path can become occluded (moisture, dust, debris, frozen condensation) over time resulting in reduced or complete lack of gas detection and alarming function. Routine visual inspection of the gas detector and bump testing are suggested to ensure proper gas detection and alarm function.
- ⚠ Use only genuine parts and accessories. Failure to comply may impair the operation of the product and void the warranty.

Installation

General Safety Cautions

 Failure to observe the following may cause injury to persons and/or property.

Installation must be carried out by a licenced and insured contractor and installed in areas at risk of gas leaks and higher concentrated areas e.g., near boilers, valves, or areas of critical protection, located in positions determined by those who have knowledge of gas dispersion, the process plant system and equipment involved, and in consultation with both safety and electrical engineering personnel.

Final positioning of gas detectors should be indicated by the characteristics of the gas being detected and other environmental factors. Seek advice where necessary. Take in to account the design of the air flow patterns within the area, sensors should be installed in the correct orientation as per the manufacturer's specification, and ease of access should be accounted for to allow for any forms of maintenance throughout its operational life.

Installation must be in accordance with the recognized standards of the appropriate authority in the country concerned. For Europe, see EN 60079-29-2, EN 62990-2 and/or EN44554-4. For installations in North America, the National Electrical Code (NFPA 70) should be strictly observed. All appropriate local and national regulations should be observed.

EMI and RF Interference Considerations

All electronic devices are susceptible to EMI (Electromagnetic Interference) and RFI (Radio Frequency Interference). Our products are designed to reduce the effects of these interferences. However, there are still circumstances and levels of interference that may cause the equipment to respond to these interferences.

Reduce the possibility by:

- Avoiding installation locations near high foot traffic and high energy equipment.
- Confirming equipment is properly grounded if required and shielded cabling.

Coverage

50ft radius per detector is a reasonable guide, therefore multiple detectors may be required to adequately protect property and persons. However, coverage should be determined by those who have knowledge of gas dispersion, target gas characteristics, the environment, process plant system(s) and intended functions etc., and in consultation with both safety and electrical engineering personnel.

Positioning

There are no specific standards governing gas detector locations (unlike fire detection systems); there are, however, general guidance documents. The most relevant being *IEC 60079-29-2*. Much of what it covers is also relevant to toxic gas & oxygen monitoring equipment. Recommended heights may vary based on air flow and other environmental conditions in addition to the proposed application, location, and target gas.

The composition of the target gas and its density relative to air are used as the basis for the recommended height of sensors.

Generally, the installation height of a sensor for a heavy gas (e.g., LPG) would be close to the lowest point in the area, and for a light gas (such as methane or hydrogen) would be close to the highest point in the area.

These typical heights may vary based on application.

Target Gas	Typical Install Height
Carbon Monoxide (CO)	Breathing Zone – 4 - 6ft from ground level.
Nitrogen Dioxide (NO ₂)	Breathing Zone or, Low Level - 1ft from ground level.
Carbon Dioxide (CO ₂)	Breathing Zone - 1700mm (5ft 6") from ground level
Natural Gas (NG) / Methane (CH ₄)	High Level - 300mm (1ft) from ceiling
Propane / Butane (LPG)	Low Level - 300mm (1ft) from ground level
Hydrogen (H ₂)	High Level - 300mm (1ft) from ceiling
Oxygen (O ₂)	Breathing Zone – 4 - 6ft from ground level.

Observe the following also.

- Ease of access to the equipment for functional testing and servicing.
- How gas may behave due to natural or forced air currents.
- Any regulation/standard/code that locations are bound by.

Mounting Instructions

- ⚠ Position at a location with minimum noise, vibration, and environmental variation.
- ⚠ Damage when creating entry points or attempting to remove the circuit board may void any warranty.
- ⚠ Avoid environmental conditions outside of this specification that could potentially impede the accuracy and operation of the equipment such as condensation; vibration; temperature, pressure, the presence of other gases, electromagnetic interference, and draft zones.

1. Carefully remove the front cover from the unit by using an M3 hex key supplied.
2. Using the rear base - mark mounting holes to the wall or align with a gang/pattress box.
3. Fixing straight to wall – drill 0.2" (5mm) hole, insert plugs and use the four screws (No.4 Pozi) provided.
There are 2x pre-fractured knockouts for cable entry on the rear of the base.
For 0.5" conduit mounting use the 2x knockouts on the top and bottom.
Two indents are visible and can be drilled out as necessary.

4. After executing the mounting/connections – secure the front cover with all bolts and insert the security caps provided.

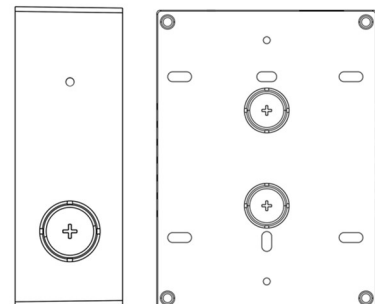

Circuit Board Overview

1. S2 Gas Sensor - Replaceable module
2. S1 Gas Sensor - Replaceable module
3. RS485 Configuration dip-switches
Protocol / Network Address / Baud Rate
4. Power Input
12-32V AC/DC (Nominal 24V)
5. RS-485 Digital Output
Modbus RTU or BACnet MS/TP
6. Signal Relay Output
1A, 60V max
7. AN1 & AN2 Analog Output (mA or V)
8. 3-Way Dip-switch
 - AN1 & AN2 Voltage or Current Output
 - RS485 120ohm Termination Resistor

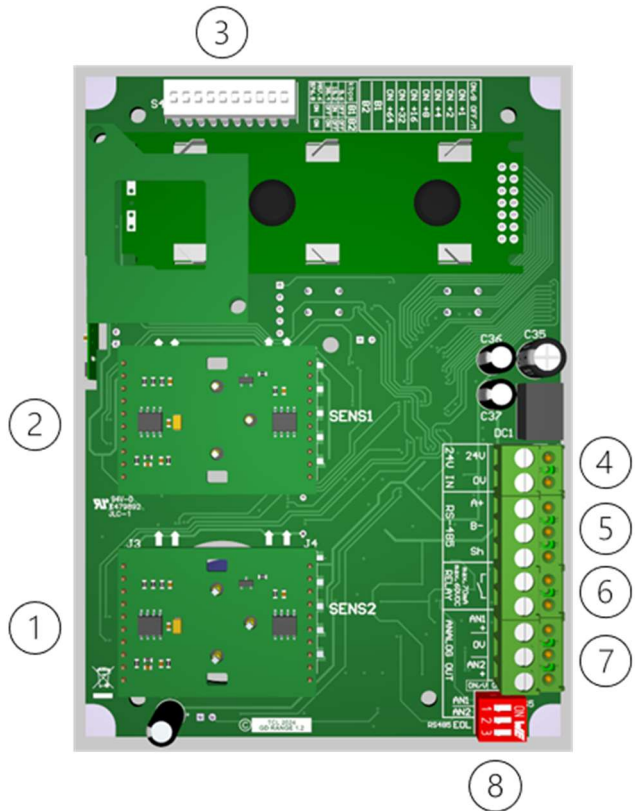

Power & Digital RS485 Wiring

- ⚠ Warranty may be void if damage occurs to the circuit board from use of solid core wire attached directly to terminals.
- ⚠ The equipment requires a continual supply of electrical power – it will not work without power.

The equipment is powered by low voltage 12-24V DC or AC.

Cable specifications ultimately determine the distance the sensors can be mounted away from a control panel or power supply. Consider voltage drops due to cable resistance and strip the cables as short as possible ensuring bare wires, e.g., wire shields, do not contact with the circuit board (risk of short-circuit).

For the Modbus RS-485 or BACnet MS/TP network use a 3-core, 2 twisted pair + ground, shielded cable with 120 Ω characteristic impedance. Any cable with similar characteristics can be used to connect all the devices together. Daisy chain wires running to additional monitors – 127 sensors max per cable run. First and last device in bus requires a termination resistor. Use RS485 EOL switch to terminate by turning ON.



All wiring should be run within properly grounded (earth or safety) conduit. The cable shield should be connected to earth ground at the controller/power supply that is providing power to the equipment.

Low voltage wiring must not be within the same conduit as any line/mains voltage wiring.

To ensure optimal performance of the network ensure the following guidelines are implemented:

- Ensure the equipment is configured in a single bus topology, connecting multiple buses in parallel or branching multiple units from the main bus, may introduce impedance mismatches, reflections and/or signal distortions.
- Ensure equipment at each end of a bus has the 120 Ω terminating resistor switch enabled.
- Ensure A+/B- signal polarity is maintained throughout the network.
- Connect shield wires to earth/ground of the central control panel if no shield connection is present.
- Ensure cable shield integrity is maintained throughout the network.
- Do not use shield connection for signal ground. Use cable that provides dedicated ground conductor for signal ground. Connect signal ground to (0V/GND) terminal.

RS485 Dipswitch Settings

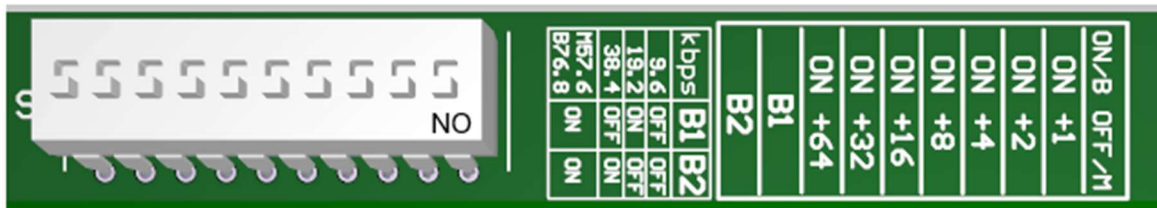

Switch	Function	Label	Parameter
1	RS485 Selection	OFF/M ON/B	Off/M: Modbus RTU / On/B: BACnet MS/TP
2-8	Slave ID	-	Achieved by adding binary switch values together. Example #2 ON + #4 ON = ID: . (Max. 16)
9-10	Baud Rate	B1 / B2	On/Off configuration achieves either. 9600, 19200, 38400 or 57600 (Modbus) / 76800 (BACnet)

Analog Output Wiring

⚠ Outputs are scaled to the high alarm concentration level.

Two linear voltage or current output terminals are available and often used to regulate external fan speed controllers. The AN1 & AN2 dipswitch will change from 4-20mA to 2-10V. The output is scaled to the Alarm H (high) setpoint, and the gas closest to the Alarm H will take priority and drive the speed (default).

Configure dipswitches to select current (OFF) or voltage (ON) for each output (AN1 and AN2).

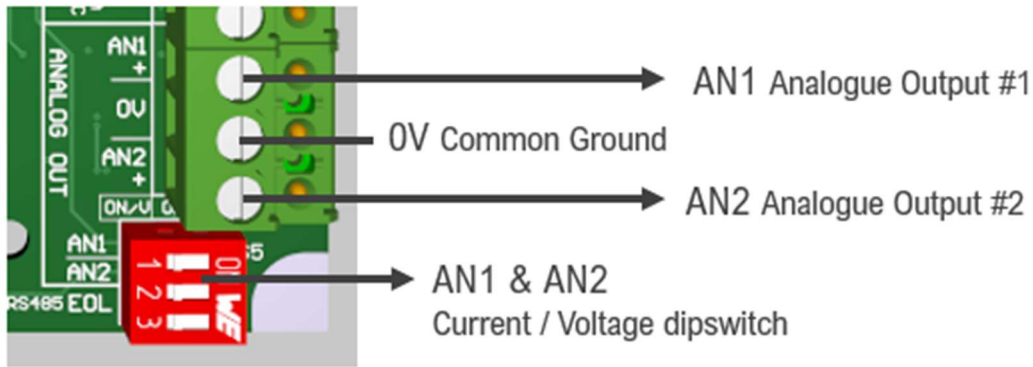

Gas Concentration to High Alarm Level
(See section: Configuration List)

	0-100%		20-100%	
0%	0v	0mA	2v	4mA
100%	10v	20mA	10v	20mA

Operation

Initial power-up

- ⚠ Before leaving the instrument for normal operation, check configuration for proper settings.
- ⚠ Allow the equipment to stabilise for at least 2 hours (preferably 24 hours) upon power up.

During initial powering, the device will go through a 60s start-up count-down sequence.

Once initialized, normal/measuring mode will be displayed.

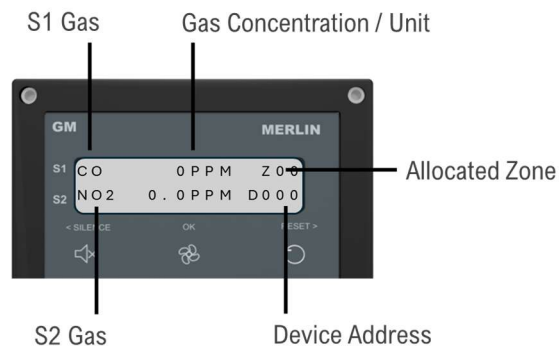

LED Indication Status



Low Gas Alarm

In low alarm the red LED will blink



High Gas Alarm

In High alarm the red LED will be solid and display will turn Red.

Visual indication of the gas detector status is provided by a single RGB colour LED. Detector condition and corresponding outputs are shown below (as **factory set condition**).

Condition	LED	Description	Buzzer	1A Relay
Warm-up		Green LED Blink	OFF	-
Normal		Green LED On	OFF	-
Alarm Low		Red LED Blink	BEEP (*Default OFF)	-
Alarm High		Red LED On	ON (*Default OFF)	ON
Fault		Yellow On	BEEP (*Default OFF)	-
Cal. Ready		Blue LED Blink	OFF	-
Cal. OK		Blue/Green Blink	BEEP (*Default OFF)	-
Cal. Fail		Blue/Yellow Blink	BEEP (*Default OFF)	-

IMPORTANT: * Buzzer is OFF as default and can be turned on from the configuration menu.

User Button Functions

User interaction with the detectors is accomplished using accessible buttons on the fascia.

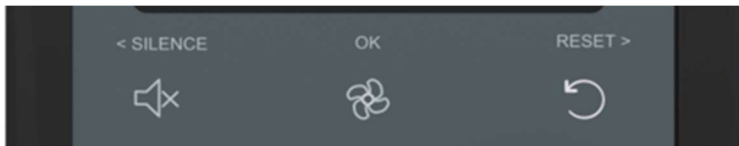

Button	Description
< SILENCE	<ul style="list-style-type: none"> - Silence the audible alarm. - Toggle left.
OK	<ul style="list-style-type: none"> - Manual Override. - Confirm selection. - Toggle Centre
RESET >	<ul style="list-style-type: none"> - Toggle right.
< SILENCE & RESET >	<ul style="list-style-type: none"> - Hold to prompt Configuration Menu

Manual Override

Blinking M = Manual Fan Override



Press [OK] for 5s to activate manual override.
Press < > to select the override time (minutes).
Press < > to select if the signal relay is included

Analog outputs will drive at 100% for the selected time. The signal relay will be activated if selected.

'M' will blink on the equipment for the duration of the override.
To cancel the override, press [OK] for 5 secs and select 0 minutes.

Temperature Alarm

Blinking T = Temperature Alarm



If the temperature alarms are set to ON, a 'T' indication will blink on the display. There are no output changes, but configurations can be made over a network. This is an indication only; ambient temperatures should be measured and the unit calibrated to match. It may take up to 6 hours energised to stabilise temperature readings.

Access Configuration Menu

1. To enter the settings menu, hold the <SILENCE & RESET> buttons for 5 sec.
2. Use all 3 buttons to scroll through numbers (0-9) and **Enter Code 753**.
3. Hold the OK button for 3s to accept the code and enter the menu.

(Toggle using < > to access CALIBRATION or REPLACE (see Maintenance section))

4. In the configuration menu, use < > to toggle between functions and OK to select/confirm changes.
5. If adjustments are made, select [SAVE/EXIT/R] and select [SAVE & EXIT].

Configuration List & Parameters

No	Display Text	Parameter	Default	Description
01	S1: ALARM L	See section: Default Sensor Alarms		Sensor 1: Low alarm setpoint (Pre-alarm)
02	S1: ALARM H			Sensor 1: High alarm setpoint (Main alarm)
03	S2: ALARM L			Sensor 2: Low alarm setpoint (Pre-alarm)
04	S2: ALARM H			Sensor 2: High alarm setpoint (Main alarm)
05	AL H DELAY	0- 30 seconds	02	Set acknowledgement time for the high alarm to avoid false readings
06	ZONE NUMBER	0-10	00	Set Zone number (if required).
07	SIG RLY AL	L / H	H	Signal alarm relay to [L] or [H] alarm
08	SIG RLY POL	NO / NC	NC	Relay polarity, normally open (NO) or normally closed (NC)
09	TEMP UNIT	°C / °F	°F	Select °C / °F
10	TEMP ADJ	-9° / +9°	0°	Offset temperature value by maximum $\pm 9^\circ$
11	TEMP AL HIGH	ON / OFF	OFF	Turn ON/OFF the temperature high alarm
12	TEMP AL H SET	77- 104° F (25- 40°C)	104° F	Set the temperature high alarm setpoint. Enabled if TEMP AL HIGH is ON.
13	TEMP AL LOW	ON/OFF	OFF	Turn ON/OFF the temperature low alarm
14	TEMP AL LOW SET	32- 59° F (0- 15°C)	32° F	Set the temperature low alarm setpoint. Enabled if TEMP AL LOW is ON.
15	DEADBAND	ON / OFF	ON	Gas readings hovering around zero are displayed as zero.
16	BUZZER	ON / OFF	OFF	Audible buzzer upon AL H condition.
17	SERVICE MSG	OFF / 6/12/18	12	Calibration/Service Reminder.
18	ANALOG RANGE	0-100% 20-100%	20-100%	Configure Analog Output - 0-100% = 0-10v / 0-20mA - 20-100% = 2-10v / 4-20mA
00	SAVE/EXIT/R	BACK TO MENU EXIT W/O SAVE SAVE & EXIT RESET & EXIT		Return to the menu Exit without saving Save settings and exit Exit and reset to default settings

Default Sensor Alarms

- ⚠ Users should check and adjust alarms according to any local regulation and/or code.
 ⚠ **AGS** accepts no responsibility for alarm configuration.

Target Gas	Alarm Low	Alarm High	Parameter	*Hysteresis
Carbon Monoxide (CO)	▲ 25 ppm	▲ 100 ppm	10 - 250ppm	10%
Nitrogen Dioxide (NO ₂)	▲ 0.5 ppm	▲ 2.0 ppm	0.5 - 10ppm	10%
Methane (CH ₄) Nat. Gas	▲ 8% LEL	▲ 10% LEL	3.0 - 90% LEL	10%
Hydrogen (H ₂)	▲ 8% LEL	▲ 10% LEL	3.0 - 90% LEL	10%
Butane / Propane (LPG)	▲ 8% LEL	▲ 10% LEL	3.0 - 90% LEL	10%
Oxygen (O ₂) Depletion	▼ 19.5% V/V	▼ 18.5% V/V	0-25 % V/V	2%

ppm: Parts Per Million / **% LEL**: Lower Explosive Limit / ▼ Falling Alarm / ▲ Rising Alarm

* All alarms have a % hysteresis built in to avoid changing multiple states when gas concentrations are hovering around the alarm level, i.e., if a CO alarm is triggered at ▲20ppm rising, the alarm indications will be displayed until the gas concentration drops below 18ppm 10% hysteresis.

End Of Life (Replace) Indication

- ⚠ At the end of its life, the equipment must be decommissioned and replaced immediately.
 The GM is fitted with replaceable sensor modules with end-of-life (EOL) tracking. The end of life is a safety feature that monitors the time remaining before the sensor has reached the end of life.

When the end of life is reached, and the monitor will display a message [REPLACE]. To clear the end-of-life message the sensing module must be replaced. See section: Disable/Replace Sensor Module.

Product	Expected EOL (dependent on environmental conditions)	EOL Indication
Carbon Monoxide (CO)	7-10	7
Nitrogen Dioxide (NO ₂)	2-4	2
Methane (CH ₄) Nat. Gas	>10	10
Hydrogen (H ₂)	>10	10
Butane / Propane (LPG)	>10	10
Oxygen (O ₂) Depletion	>5	5

Commissioning

Overview

We recommend all gas detection equipment be commissioned by competent/trained engineers. Gas detectors are factory calibrated when shipped under ambient conditions, however, we recommend the detectors response and alarm signals are tested and validated once installed and subsequently every 6-18 months thereafter to retain optimum safety.

During Commissioning

- Check installation, mounting, cable entry, position.
- Check the power supply voltage and indication.
- Check/perform calibration.
- Check indications for proper operation.
- Check buzzer and relay operation.
- Check signal transmission to the BMS/central controller, where appropriate.

Regular maintenance and calibration of the sensors by trained technicians is strongly recommended. Inspections and services should be documented and executed at regular intervals with records in place. The frequency must be determined and observed by the person responsible for the gas warning system according to all regulatory, code and legal requirements. The inspection interval is normally 6 to 18 months to retain optimum safety. The date for the next maintenance should be affixed to the equipment sensor.

Our equipment is designed to operate in a wide range of harsh environments and conditions. However, it is important that exposure to high concentrations of solvent vapours is avoided, both during storage and operation. Regular maintenance and calibration of the sensors by trained technicians is strongly recommended. Inspections and services should be documented and executed at regular intervals with records in place.

The frequency must be determined and observed by the person responsible for the gas warning system according to all regulatory, code and legal requirements. The inspection interval is normally 6 to 18 months, and a service reminder can be set following the procedure in the Menu section.

The date for the next maintenance should be affixed to the equipment sensor.

Interval	Description
During commissioning	Check installation, orientation, mounting, cable entry & wiring. Check/perform calibration. Check indications for proper operation. Check buzzer and relay operation. Check signal transmission to the BMS/central controller, where appropriate.
**Every 6-18 months	Inspection by trained service personnel. Calibrate, bump, or change the sensor with a factory calibrated one.
As required	Replace sensor modules.

** This can vary by sensor type, application, environment and national or local regulation/code.

Alarm Test

An Alarm test can be carried as follows as part of the system commissioning.

Follow the procedure in the Setting Menu section to enter the code **813**. Once the code is accepted use the < and > buttons to access **Alarm Test** and press OK.

The GM will automatically return to normal operation gas levels simulated in the high alarm condition for 10 seconds during which time the signal relay will be activated and the system can be tested in an alarm condition.

Maintenance

Service Reminder

The service message is factory set as OFF and can be set up from the configuration menu. The service message acts as a reminder to carry out a periodic check of the sensor. Once a service message has been set and the period has been reached, an indication (S) will be displayed on the screen.

Flashing S = Service Message Reminder



The planned maintenance schedule should now be carried out according to industry and calibration procedures.

All inspection calibration/bump testing records should be documented.

The frequency must be determined and observed by the person responsible for the gas warning system according to all regulatory, code and legal requirements.

Reset Service Reminder

In the configuration menu, go to the [SERVICE MESSAGE] setting and select the required period before the next service, now [EXIT/SAVE] to initialise the next service reminder.

Cleaning the Equipment

- ⚠ Concentrations of alcohol found in many products may damage, deteriorate or affect the gas sensing elements such as wine; deodorants; stain removers and thinners. Other gases and substances to avoid are corrosives (i.e. chlorine & hydrogen chloride); alkali metals; basic or acidic compounds; silicones; tetraethyl lead; halogens and halogenated compounds!

Keep your Detector in good working order

- Remove any dust/debris from the outer enclosures regularly using a slightly damp cloth.

- Never use detergents or solvents to clean your device(s).
- Never spray air fresheners, hair spray, paint or other aerosols near the detectors.
- Never paint the device(s). Paint will seal vents and interfere with the equipment.

Replace or Disable Gas Sensor S1 or S2

Follow the procedure in the Setting Menu section to enter the code 753.

Once the code is accepted use the < and > buttons to access **REPLACE** and press OK.

If only a single gas type is required, S1 or S2 can be disabled. In addition to replace a sensor, first disable the sensor you wish to replace, remove and then install the new sensor, then **ENABLE**.

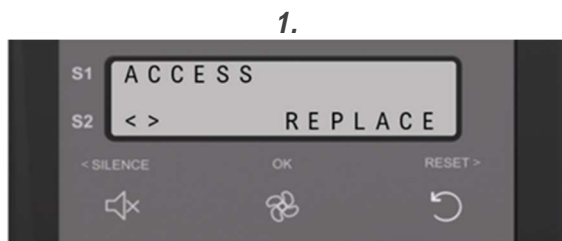

Once the code is accepted use the < and > buttons to access **REPLACE** and press Ok.

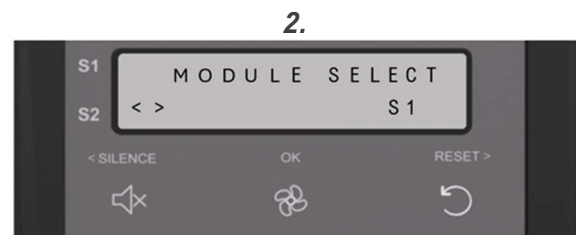

Select the module S1 or S2 using the < > buttons, press OK to confirm.

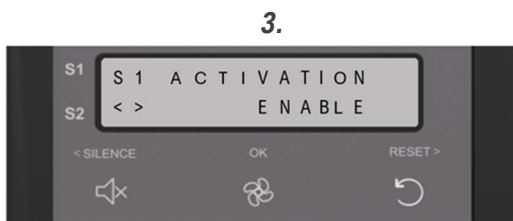

Select Enable or Disable using the < > buttons, press OK to confirm



Select Yes or No using the < > buttons, press OK to confirm.

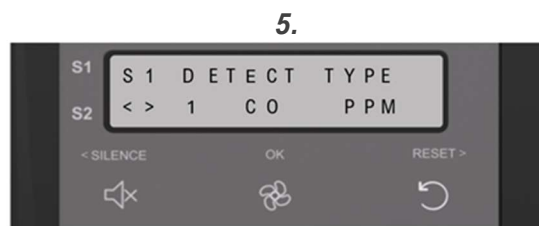

Select the detected gas type CO or NO2, press OK to confirm.

Now press Ok and then < press OK to select **BACK** and wait 10 sec for timeout or press Ok to return to normal operation.

Calibration

General Safety Statements

- ⚠ Gas mixtures must be prepared using equipment traceable to N.P.L / ISO standards.
- ⚠ Ensure all test gas is within the expiration date.
- ⚠ Take note of any material safety data sheet accompanying test gases and equipment.
- ⚠ Before starting the calibration procedure, ensure the environment is free of any gas that may affect the result.
- ⚠ Acknowledge any alarms or faults before attempting to begin the calibration process.
- ⚠ At elevations higher than 6,560' (2,000m), calibration will result in a lower reading.
- ⚠ Give at least seven (7) minutes between testing the same unit or until gas has fully dispersed.
- ⚠ Sensors should be calibrated if the measuring range has been exceeded, which can shorten the sensor lifetime and/or reduce its sensitivity.
- ⚠ Ensure the device orientation is maintained when performing calibration.
- ⚠ Do not apply gas during the [ZERO] and make sure the environment is free of any gas that may affect the calibration result. wait until a beep is heard before moving on.
- ⚠ Calibration consists of zero and span adjustments, it is not possible to adjust only one.

Calibration Procedure

To enter calibration, enter configuration menu, use the < > buttons to access [Calibration] and press [OK].

1.



Use the < and > buttons to select the module to be calibrated S1 or S2 and press OK.

2.

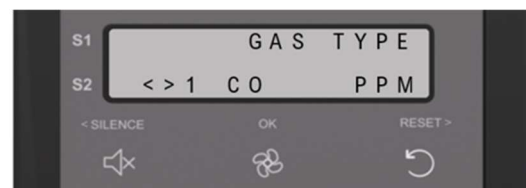

Press OK to confirm the gas type.

3.



Press OK to start the calibration.

4.

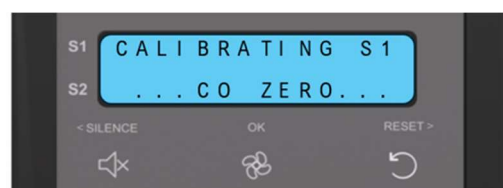

When calibration starts, the screen will turn blue.

When instructed, fit pipe direct to the gas inlet as detailed below and apply gas to the appropriate sensor within the range specified. Calibration is recommended to be performed as per local code requirements and must be carried out following the specified conditions and using equipment as detailed below.

Target Gas	Formula	Concentration	Balance/Mix	Flow Rate	Application Time
Carbon Monoxide	CO	50~150ppm	Air	0.3-0.5L Per/Min	<120s
Nitrogen Dioxide	NO ₂	2~5ppm			
Methane	CH ₄	8 – 20% LEL			
Hydrogen	H ₂	8 – 20% LEL			
Propane (LPG)	C ₃ H ₈	8 – 20% LEL			

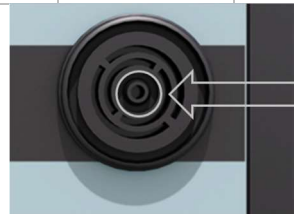

Apply gas direct to S1 or S2 sensor vent

After 60-120 seconds check the gas value is stable and no longer rising, now use the ↑ ↓ buttons to adjust the value to exactly match the test gas bottle value, the example below is a reading using a 120ppm calibration gas.

Calibration Success [OK]

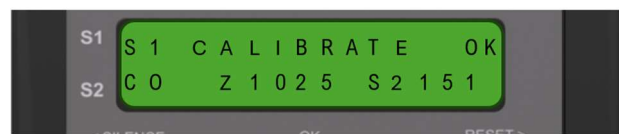
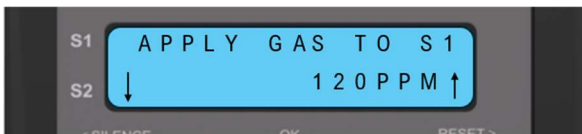

Press OK to complete the calibration. If you would like to exit the calibration without applying any changes remove the gas and press OK to display [NOK].

Calibration failed [NOK]



NOK displayed in yellow indicates the calibration has failed and results haven't been saved, the calibration should be repeated following the parameters as specified at the start of the procedure.

Now press OK and then < to select BACK, wait 10 sec for a time out to return to normal operation or Press OK to return to the Menu.

If the sensor is faulty and cannot be calibrated, the sensor module can be replaced. As a final calibration check, it is recommended to perform a bump test.

System Bump Test

General information

Gas response checks are often referred to as a 'bump test'.

Bump tests are important to make sure a device can detect a release of gas as early as possible. The aim of the bump test is to make sure a detector is working at its optimum by briefly exposing the unit to a known concentration of the target gas that usually exceeds the highest alarm point. If the detector goes into alarm and all signals/outputs activate, then the system is working safely. If the system fails to operate as intended in an alarm state, the gas detector must not be used until a full inspection and has been conducted. NFPA requires all gas detectors to be tested annually and that the test results be recorded on site and available to inspectors. A detector may visually appear in good working order, but its sensitivity and accuracy can be inhibited by external factors. Dust, humidity, temperature fluctuations, cleaning products, contaminants, exposure to its target gas or sensor drift (ageing) can cause a decline in sensitivity, accuracy, and eventual failure. Regular bump tests are important to make sure the detector can detect a release of gas as early as possible and usually takes seconds (gas type dependant i.e., CO sensors will take over a minute) and is often completed alongside a scheduled fire alarm test, however the frequency should be determined following an appropriate risk assessment by the end user. We recommend testing detectors every 12-18 months along with the regular fire test procedures and coincide with the annual service message prompted on the detection system after each year of service/operation.

Bump Test Procedure

- ⚠ Take normal precautions when using cylinders, they should always be stored in the vertical position and secured to prevent them from falling over.
- ⚠ Ensure valve/regulators are screwed and secured tight before use and ensure valves are closed after use.
- ⚠ Ensure all test gas is within the expiration date.
- ⚠

The bump test must be carried out following the specified conditions and using equipment as detailed below.

Target Gas	Formula	**Concentration	Balance/Mix	Flow Rate	Application Time
Carbon Monoxide	CO	150 ppm	Air	0.3 - 0.5L Per/min	<120s
Nitrogen Dioxide	NO ₂	5ppm			
Methane	CH ₄	20% LEL			
Hydrogen	H ₂	20% LEL			
Propane (LPG)	C ₃ H ₈	20% LEL			

**Bump test concentrations must be higher than the set alarm level but not exceed the measuring range.

Open the gas valve and apply gas to the inlet nipple of the sensor vent until an alarm is triggered, during this time you should observe the gas level rising and stabilising and response time.

Check the monitor goes into alarm and displays the applied gas correctly, in addition, consider the response time in accordance with the sensor specifications. If the response exceeds the time specified, the sensor module may need to be replaced.

If the monitor is displaying an incorrect gas level, follow the Calibration Procedure section.

Trouble Shooting

Fault Indications

If a fault occurs with the gas sensing module an error code will be displayed as shown below. Additional fault-finding error codes are listed in the Modbus/BACnet functionality document.



Error Code F!!	Description
07	S1 Wrong Type
08	S1 Module Missing
09	S2 Wrong Type
10	S2 Module Missing

Additional Information

Sensor Principle - Electrochemical

Electrochemical sensors measure the partial pressure of gases under atmospheric conditions. The monitored ambient air diffuses through a membrane into the liquid electrolyte in the sensor. The electrolyte contains a measuring electrode, a counter-electrode, and a reference electrode. An electronic “potentiated” circuit ensures a constant electrical voltage between measuring electrode and reference electrode. Voltage, electrolyte, and electrode material are selected to suit the gas being monitored so that it is transformed electrochemically on the measuring electrode and a current flow through the sensor. This current is proportional to the gas concentration. At the same time, oxygen from the ambient air reacts at the counter electrode electrochemically. The current flowing through the sensor is amplified electronically, digitized, and corrected for several parameters (e.g., the ambient temperature).

Sensor Principle - Catalytic

When a flammable gas, such as methane, propane, or hydrogen, enters the sensor, it combusts on the active bead's surface. This reaction produces heat, which increases the bead's temperature. As a result, the bead's resistance changes, and this difference in resistance is measured and translated into a gas concentration reading. The reference bead, which does not react with the gas, is used to compare temperature changes, providing a baseline for accuracy. This technology is reliable because it directly detects the heat generated by combustion, making it effective in environments where explosive gas leaks are a risk. The underlying concept might sound straightforward, but the engineering and precision behind catalytic bead sensors ensure consistent and reliable readings, which can mean the difference between safety and danger in hazardous environments.

BACnet Functionality

Parity: None / Data-Word length: 8-bit / Stop bit: 1

BACnet Interoperability Building Blocks Supported

Description	BIBB	Comments
Read Property	DS-RP-B	
Read Property Multiple	DS-RPM-B	
Write property	DS-WP-B	
Dynamic Device Binding	DM-DDB-B	Execute who is / Initiate I am
Dynamic Object Binding	DM-DOB-B	
Device Comm Control	DM-DCC-B	
Reinitialize Device	DM-RD-B	

BACnet Standard Object Types Supported

Object	No Of Instance	Instance Assignments
Device Object	1	
Analog Input (AI)	4	AI-1: [S1] Gas Type AI-2: [S2] Gas Type AI-3: Temperature AI-4: Humidity
Analog Output (AO)	2	AO-1: Analog output 1 AO-2: Analog output 2
Analog Value (AV)	14	AV-1: S1 Low Alarm AV-2: S1 High Alarm AV-3: S2 Low Alarm AV-4: S2 High Alarm AV-5: High Alarm Delay AV-6: Zone Number AV-7: Signal Relay Follows AV-8: Temperature Offset AV-9: Temperature High Alarm AV-10: Temperature Low Alarm AV-11: Service Warning AV-12: Service Time Left AV-13: S1 Module Working Time Left AV-14: S2 Module Working Time Left
Binary Output (BO)	1	BO-1: Signal Relay
Multi-State Value (MSV)	6	MSV-1: Temperature Unit MSV-2: Error Codes MSV-3: Deadband MSV-4: Audible Alarm MSV-5: Temperature High Alarm Enable MSV-6: Temperature Low Alarm Enable

BACnet Standard Object Types Supported

Property Name / ID	Default	Read/Write
Object Identifier	OBJECT_DEVICE: Vendor No x1000 & Mac Address	R/W
Object Name	GM Range	R/W
Object Type	8: Object Device	R
System Status	0: Operational	R

Vendor Name	American Gas Safety LLC	R
Vendor Identifier	1447	R
Model Name	Merlin GM 100	R
Firmware Revision	1.0.0	R
Application SW Version	1v0	R
Protocol Version	1	R
Protocol Revision	18	R
Protocol Services Supported	Binary List	R
Object List	Object Array	R
Max APDU Length	480	R
Segmentation Support	3: None	R
APDU Timeout	3000	R
Number APDU Retries	3	R
Database Revision	0	R
Description	Gas Detection	R/W
Location	Location	R/W
Max Master	127	R
Max Info Frames	1-16	R
Link Speed	(Baud Rate Indicator)	R
Mac Address	(Network ID)	R
1000-Proprietary (Factory Reset)	0 (AI / AO / AV / BO / MSV ONLY) 1: Prompt Reset	R/W

Analog Input Objects (AI)

Property Name / ID	Default	R/W
Object Identifier	OBJECT_ANALOG_INPUT: #	R
Object Name	AI-1: "Gas Formula" AI-2: "Gas Formula" AI-3: Temperature AI-4: Humidity	R
Object Type	0: Object Analog Input	R
Present Value	REAL	R
Status Flag	0000	R
Event State	NORMAL	R
Out-of-Service	FALSE	R/W
Units	AI-1: Gas Type Dependant (ppm / %LEL etc.) AI-2: Gas Type Dependant (ppm / %LEL etc.) AI-3: DEGREES FAHRENHEIT AI-4: PERCENT RELATIVE HUMIDITY	R
Description	N/A	R/W

Analog Output Objects (AO)

Property Name / ID	Default	R/W
Object Identifier	OBJECT_ANALOG_OUTPUT: #	R
Object Name	AO-1: Analog Output 1 AO-2: Analog Output 2	R
Object Type	1: Object Analog Output	R
Present Value	Real	R
Status Flag	0000	R
Event State	0: Normal	R
Out-of-Service	False	R/W
Units	AO-1: PERCENT AO-2: PERCENT	R

Analog Value Objects (AV)

Property Name / ID	Default	R/W
Object Identifier	OBJECT_ANALOG_OUTPUT: #	R
Object Name	AV-1: S1 Low Alarm AV-2: S1 High Alarm AV-3: S2 Low Alarm AV-4: S2 High Alarm AV-5: High Alarm Delay (0-99) AV-6: Zone Number (0-10) AV-7: Signal Relay Follows (1: Low Alarm, 2: High Alarm) AV-8: Temperature Offset (-9 to +9) AV-9: Temperature High Alarm AV-10: Temperature Low Alarm AV-11: Service Warning (0: OFF, 6,12,18 Months) AV-12: Service Time Left AV-13: S1 Module Working Time Left AV-14: S2 Module Working Time Left	R
Object Type	2: Object Analog Value	R
Present Value	Real	R- R/W
Status Flag	0000	R
Event State	0: Normal	R
Out-of-Service	False	R/W
Units	AV-1: Gas Type Dependant (PPM / %LEL etc.) AV-2: Gas Type Dependant (PPM / %LEL etc.) AV-3: Gas Type Dependant (PPM / %LEL etc.) AV-4: Gas Type Dependant (PPM / %LEL etc.) AV-5: SECONDS AV-6: NO UNIT AV-7: NO UNIT AV-8: NO UNIT AV-9: DEGREES FAHRENHEIT AV-10: DEGREES FAHRENHEIT AV-11: MONTHS AV-12: HOURS AV-13: DAYS AV-14: DAYS	R

Binary Output Objects (BO)

Property Name / ID	Default	R/W
Object Identifier	OBJECT_BINARY_OUTPUT: #	R
Object Name	BO-1: RELAY	R
Object Type	4: Object Binary Output	R
Present Value	0: OFF 1: ON	R
Status Flag	0000	R
Event State	NORMAL	R
Out-of-Service	FALSE	R/W
Polarity	0: Normal 1: Reversed	R/W

Multi-State Value (MSV) Temperature Unit

Property Name / ID	Default	R/W
Object Identifier	OBJECT_MULTI_STATE_VALUE:1	R
Object Name	Error Codes	R
Object Type	19: Object Multi State Value	R
Present Value	2: (°Fahrenheit)	R/W
Status Flag	0000	R
Event State	NORMAL	R
Out-of-Service	FALSE	R/W
Number of States	2	R
States	1: °C 2: °F	R

Multi-State Value (MSV) Error Codes

Property Name / ID	Default	R/W
Object Identifier	OBJECT_MULTI_STATE_VALUE:2	R
Object Name	Error Codes	R
Object Type	19: Object Multi State Value	R
Present Value	1: (No Error)	R
Status Flag	0000	R
Event State	NORMAL	R
Out-of-Service	FALSE	R/W
Number of States	10	R
States	1: No Error 2: EEPROM Error 3: Temperature Sensor Error 4: DAC Error 5: M1 Error 6: M2 Error 7: S1 Wrong Type 8: S1 Module Missing 9: S2 Wrong Type 10: S2 Module Missing	R

Multi-State Value (MSV) Deadband

Property Name / ID	Default	R/W
Object Identifier	OBJECT_MULTI_STATE_VALUE:3	R
Object Name	Deadband	R
Object Type	19: Object Multi State Value	R
Present Value	1: (OFF)	R/W
Status Flag	0000	R
Event State	NORMAL	R
Out-of-Service	FALSE	R/W
Number of States	2	R
States	1: OFF 2: ON	R

Multi-State Value (MSV) Audible Alarm

Property Name / ID	Default	R/W
Object Identifier	OBJECT_MULTI_STATE_VALUE:4	R
Object Name	Audible Alarm	R
Object Type	19: Object Multi State Value	R
Present Value	1: (OFF)	R/W
Status Flag	0000	R
Event State	NORMAL	R
Out-of-Service	FALSE	R/W
Number of States	2	R
States	1: OFF 2: ON	R

Multi-State Value (MSV) Temperature High Alarm Enable

Property Name / ID	Default	R/W
Object Identifier	OBJECT_MULTI_STATE_VALUE:5	R
Object Name	Temperature High Alarm Enable	R
Object Type	19: Object Multi State Value	R
Present Value	1: (OFF)	R/W
Status Flag	0000	R
Event State	NORMAL	R
Out-of-Service	FALSE	R/W
Number of States	2	R
States	1: OFF 2: ON	R

Multi-State Value (MSV) Temperature Low Alarm Enable

Property Name / ID	Default	R/W
Object Identifier	OBJECT_MULTI_STATE_VALUE:6	R
Object Name	Temperature Low Alarm Enable	R
Object Type	19: Object Multi State Value	R
Present Value	1: (OFF)	R/W
Status Flag	0000	R
Event State	NORMAL	R
Out-of-Service	FALSE	R/W
Number of States	2	R
States	1: OFF 2: ON	R

Modbus Functionality

Parity: None / Data-Word length: 8-bit / Stop bit: 1

Operation

Register/Address	Description	Notes	Read/Write
40000-40030	Reserved		
40031	Baud Rate	Type: uINT, Factor:1 9600 (Default), 19200, 38400, 57600 via dipswitch	R
40032	Address	Type: uINT, Factor:1, 0-127 via DIP Switch	R

40033	Model number	Type: uINT, Factor:1	R
40034	N/A	N/A	R
40035	*S1 Gas Concentration	Type: INT, Factor: 1, Unit: Gas Type Specific (PPM, %LEL etc.)	R
40036	*S2 Gas Concentration	Type: INT, Factor: 10, Unit: Gas Type Specific (PPM, % LEL etc.)	R
40037	Temperature	Type: INT, Factor: 10, Unit: °C/°F	R
40038	Humidity	Type: INT, Factor: 10, Unit: %RH	R
40039	Analog Output 1	Type: INT, Factor: 1, Unit: %	R
40040	Analog Output 2	Type: INT, Factor: 1, Unit: %	R
40041	*S1 Low Alarm Setpoint	Type: uINT, Factor: 1, Unit: Gas Type Specific Range: Gas Type Specific	R/W
40042	*S1 High Alarm Setpoint	Type: uINT, Factor: 1, Unit: Gas Type Specific Range: Gas Type Specific	R/W
40043	*S2 Low Alarm Setpoint	Type: uINT, Factor: 10, Unit: Gas Type Specific Range: Gas Type Specific	R/W
40044	*S2 High Alarm Setpoint	Type: uINT, Factor: 10, Unit: Gas Type Specific Range: Gas Type Specific	R/W
40045	High Alarm Delay	Type: uINT, Factor: 1, Unit: sec, Default: 2 (0-99)	R/W
40046	Zone Number	Type: uINT, Factor: 1, Default: 2 (0-10)	R/W
40047	Signal Relay Follows	Type: uINT, Factor: 1, Default: 2 (1=Low Alarm, 2=High Alarm)	R/W
40048	Temperature Offset	Type: INT, Factor: 1, Default: 0 (-9 to +9)	R/W
40049	Temperature High Alarm Setpoint	Type: INT, Factor: 10, Unit: °C/°F Default: 104°F / 40°C (77-104°F) (25-40°C)	R/W
40050	Temperature Low Alarm Setpoint	Type: INT, Factor: 10, Unit: °C/°F Default: 32°F / 0°C (32-59°F) (0-15°C)	R/W
40051	Service Warning	Type: uINT, Factor: 1, Unit: Months, Default: 12 (0=OFF, 6, 12, 18)	R/W
40052	Audible Alarm	Type: uINT, Factor: 1, Default: 0 (0=OFF, 1=ON)	R/W
40053	Signal Relay Polarity	Type: uINT, Factor: 1, Default: 1 (0=N/O, 1=N/C)	R/W
40054	Deadband	Type: uINT, Factor: 1, Default: 1 (0=OFF, 1=ON)	R/W
40055	Temperature High Alarm Enable	Type: uINT, Factor: 1, Default: 0 (0=OFF, 1=ON)	R/W
40056	Temperature Low Alarm Enable	Type: uINT, Factor: 1, Default: 0 (0=OFF, 1=ON)	R/W
40057	N/A	N/A	R
40058	Temperature Unit	Type: uINT, Factor: 1, Default: 2 (1=°C, 2 =°F)	R/W
40059	Reserved		
40060	Error Codes	1: No Error 2: EEPROM Error 3: Temperature Sensor Error 4: DAC Error	R

		5: M1 Error 6: M2 Error 7: S1 Wrong Type 8: S1 Module Missing 9: S2 Wrong Type 10: S2 Module Missing	
40061	Signal Relay Status	Type: INT, Factor: 1, (0=No alarm, 1=Alarm, relay changed status)	R
40062	Service Time Left	Type: INT, Factor: 1, Unit: Hours	R
40063	S1 Alarm Status	Type: INT, Factor: 1, (0=No alarm, 1=Low Alarm, 2=High Alarm)	R
40064	S2 Alarm Status	Type: INT, Factor: 1, (0=No alarm, 1=Low Alarm, 2=High Alarm)	R
40065	Temperature Alarm Status	Type: INT, Factor: 1, (0=No alarm, 1=Alarm)	R
40066	S1 Module Working Time left	Type: INT, Factor: 1, Unit: Days	R
40067	S2 Module Working Time left	Type: INT, Factor: 1, Unit: Days	R

Please pass this manual to the system owner/user.

Date of Installation:	
Installation Location:	
Organisation:	
Stamp/Signature of the installer:	

American Gas Safety LLC

www.americangassafety.com

Head office:

6304 Benjamin Road, Suite 502, Tampa, FL 33634

Tel: (727) 608-4375



Email: info@americangassafety.com

American Gas Safety LLC is the owner of this document and reserves all rights of modification without prior notice.